

OSR-Info Team

Kim Griffin, Director, Electronic Research Administration

Sara Krentz, Business Analyst

Melissa Mizwa, Project Administrator

OSR-Evanston Quarterly Network

August 31, 2015

Northwestern

INFOED UPGRADE & AWARD WORKFLOW

InfoEd Upgrade

- Timing
 - Planned downtime: **September 11, 2015**
 - System comes down 6 PM on September 10
 - V14 should be available Monday, September 14

InfoEd Upgrade: Training

- FFRA webinars
 - September 9th 10 AM
 - September 9th 1 PM
 - September 16th 11 AM
 - September 17th 3 PM
- See schedule register on FFRA website
<http://ffra.northwestern.edu/announcements/ieupgrade.html>

InfoEd Upgrade: New Budget Model

Modeling Neuroscience for Enhancing Memory Operations through Non-Invasive Channels (MNEMONIC) Proposal SP0034377
Ken Paller - Ctr Sleep & Circadian Biology (Department of Defense)

Budget Source View: Project Rollup subprojects: Complete Budget

Project Period: Start: 01-Oct-2015 End: 30-Sep-2017

Budget Summary [hide]

Year/Period	Increment	Periods [hide]		Type	Status	Sponsor [show]		Cost Sharing [show]		Project [hide]	
		Start	End			Total	Total	Directs	F&A	Total	
1	1	01-Oct-2015	30-Sep-2016	Budget Period *	Requested	56,238.00	-	36,400.00	19,838.00	56,238.00	
2	2	01-Oct-2016	30-Sep-2017	Budget Period *	Requested	57,693.39	-	37,342.00	20,351.39	57,693.39	
Total						113,931.39	0.00	73,742.00	40,189.39	113,931.39	

Personnel [hide]

Name	Period 1	Period 2	Direct Costs
Key Personnel			
Detail Paller, Ken PD/PI	5,000.00	5,150.00	10,150.00
Non-Key Personnel			
Detail TBD. Graduate Student	26,400.00	27,192.00	53,592.00 Remove
Subtotal Personnel:	31,400.00	32,342.00	63,742.00

[Add New Profile](#) -- Select Type -- -- Select Role -- [Add Person](#)

Non-Personnel [hide] [Add Bulk Entry](#)

Category	Period 1	Period 2	Direct Costs
Detail Services	1,000.00	1,000.00	2,000.00 Delete
Detail Supplies	1,000.00	1,000.00	2,000.00 Delete
Detail Travel-Domestic	3,000.00	3,000.00	6,000.00 Delete
Subtotal Non-Personnel:	5,000.00	5,000.00	10,000.00

[Add Item](#)

InfoEd Upgrade: New Features

- Progressive text searches
- Bulk entry budget categories
- Simplified F&A entry for subcontracts
- Budget navigation
- S2S forms preview
- Uploads

OSR Info Team at FFRA Open Labs

- **Reminder!**
Sara Krentz/Chris Rinere will be available at Open Lab sessions **Mondays: 9/14, 9/28, 10/12, etc through December**
Mudd Library 10-12 AM
- FFRA training staff host Open Labs every week

InfoEd: Award Setup Workflow

- Key features
 - New statuses for increased transparency
 - A visual award workflow map inside InfoEd
 - Companion Cognos ad hoc report
 - Metrics on award setup time will be deployed to OSR's Reports and Metrics page on the OSR website (fall 2015)

InfoEd Workflow: New Statuses

- Award under OSR Review
- Award Waiting Department
- Award Pending COI Determination
- Awarded
- Award Ready for QA
- Award QA Check Complete

InfoEd Workflow: Live Map

- A visual award workflow map allows users to see which awards are in each status
 - Award counts are hyperlinks – click the number to see the detailed list of awards in each status

OSR Award Setup

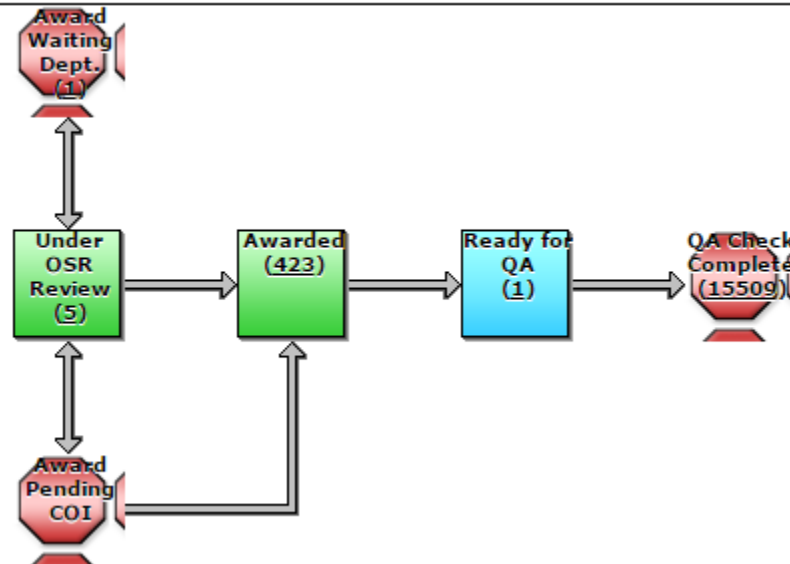











InfoEd Workflow Map (continued)

- Standard user security applies to the awards that are included in the map

Items Under: **Under OSR Review**

Records Found: **5.**

Number	Title	Investigator	Department	Assigned To	Open	Routing Status
SP0024170	Elucidating the Role of miR-31 in Retinoblastoma Invasion	Paul Bryar	Ophthalmology	<u>1</u> 		
SP0026000	Crystallization at Interfaces	Michael J Bedzyk	MCC Materials Science	<u>1</u> 		
SP0031000	Building Bone after Spinal Cord Injury: Effect of Alendronate after Teriparatide Therapy	Thomas J Schnitzer	Physical Medicine & Rehab	<u>1</u> 		
SP0031010	Filamentous haemagglutinin Proteins as Novel Toxins of Pseudomonas aeruginosa	Jonathan Paul Allen	Micro-Immuno Rsrch Operations	<u>1</u> 		
SP0031015	LRRK2R1441C dys-regulates PKA activity in the striatum that contributes to Parkinson's disease pathology and treatment	Dr. Loukia Parisiadou	Radiation Oncology Parent Acct	<u>1</u> 		

InfoEd Workflow: Action Items

- Action items facilitate the handoffs between statuses
 - If OSR requests information from the department, they will change the status to **Award Waiting Department**

Proposal SP0031010 Filamentous haemagglutinin Proteins as Novel Toxins of Pseudomonas aeruginosa

Instructions

Award Under OSR Review SP0031010

Item

System	Item	Action Item Operating Status	Number	Submitted By	Open
PT Proposal	Initial Application	Award Under OSR Review	SP0031010	Tyler Heard Dorsett	

Your Action/Decision

Next Status **Assign to:**

Comments

Please send updated budget information.

Assignment History

Assigned/Completed	Duration	Action	Who	Comments
13-Jul-2015 5:16:36 PM	Current	Award Under OSR Review	Sara L Krentz	
13-Oct-2014 4:31:56 PM/13-Oct-2014 4:31:56 PM	0 minute	Award Under OSR Review	Tyra Patrice Darville-Layne	
13-Oct-2014 4:31:55 PM/13-Oct-2014 4:31:56 PM	0 minute	Award Under OSR Review	Arthur Q Miranda	
13-Oct-2014 4:31:55 PM/13-Oct-2014 4:31:56 PM	0 minute	Award Under OSR Review	Jen Thennes	
13-Oct-2014 4:31:55 PM/13-Oct-2014 4:31:56 PM	0 minute	Award Under OSR Review	Karen Rena Richardson	
13-Oct-2014 4:31:55 PM/13-Oct-2014 4:31:56 PM	0 minute	Award Under OSR Review	Eugenie Chao	

InfoEd Workflow: Action Items (cont.)

- An email notification with a link to an InfoEd action item will be sent to the research administrator
- Once the dept is ready to send the award back to OSR, the administrator changes the status via the action item

Proposal SP0031010 Filamentous haemagglutinin Proteins as Novel Toxins of Pseudomonas aeruginosa

Instructions [I am Done](#) [Forward](#)

Award Waiting Department SP0031010

Item

System	Item	Action Item Operating Status	Number	Submitted By	Open
PT Proposal	Initial Application	Award Waiting Department	SP0031010	Tyler Heard Dorsett	

Your Action/Decision

Next Status
Award Under OSR Review

Assign to:
Schaeffer, Noah - O S R Administration

Comments

ESPR to revise budget submitted - #7777

Assignment History

Assigned/Completed	Duration	Action	Who	Comments
14-Jul-2015 1:52:17 PM	Current	Award Waiting Department	Sara L Krentz	
13-Jul-2015 5:16:36 PM/14-Jul-2015 1:52:17 PM	21 hours	Award Waiting Department	Sara L Krentz	Please send updated budget information.
13-Oct-2014 4:21:55 PM/13-Oct-2014 4:21:55 PM	0 minutes	Award Waiting Department	Tyler Heard Dorsett	

InfoEd Workflow: Delegation Options

- In V14 delegation options are more robust and differentiated
- Delegated access to Action Items
 - See items waiting for another RA
 - Complete items on behalf of another RA

InfoEd Workflow: Cognos Report

- Cognos ad hoc report will be available in the InfoEd Ad Hoc/Schools folder
- Prompts for a school, then lists all awards in the queue

Prompt

Provide values for the report you are about to run.

- * Indicates a required field.
- ◇ Points to missing information.

Level 3 Description
Provide a value:

Alumni Relations & Development
Athletics
Business and Finance
Conversion Department
Ctrl Rsrc The Graduate School
Ctrl Rsrc Undergrad General
Feinberg School of Medicine
Kellogg School of Management
McCormick Sch Engg & App Sci
Media Management Center

[Select all](#) [Deselect all](#)

Awards in Setup

Current Proposal Status: Awarded, JIT/Revisions Requested, Pre-Spending AND Project Award End Date: On or after Mar 6, 2015 AND ((PeopleSoft Project ID: missing values only AND Award Type: New) OR NOT Award Type: New) AND Level 3 Description: Feinberg School of Medicine
Project Award Start Date: Ascending order

Level 3 Description	Department Description	Level 1 for Institution Number	Institution Number	PeopleSoft Project ID	Full Name	Proposal Short Title	Originating Spon Name Level 1	Sponsor Name Level 1	Project Award Start Date	Project Award End Date	Award Type	Current Proposal Status
Feinberg School of Medicine	Endocrinology	SP0003301	PROJ0002376	60024655	Joseph Bass	Alterations of Sleep and Circa	Department of Health and Human Services	University of Chicago	05/15/2009	03/31/2015	Competing Renewal	Awarded
Feinberg School of Medicine	Sleep Disorders	SP0003301	PROJ0002451	60024942	Phyllis C Zee	Alterations of Sleep and Circa	Department of Health and Human Services	University of Chicago	05/15/2009	03/31/2015	Competing Renewal	Awarded
Feinberg School of Medicine	General Internal Med	SP0010039	SP0010039	60028515	Michael Wolf	LITog II: Health Literacy and	Department of Health and Human Services	Department of Health and Human Services	03/01/2011	02/29/2016	Competing Renewal	Awarded
Feinberg School of Medicine	Mstp Program Support	SP0013913	SP0013913	60031961	Dane M Chetkovich	Medical Scientist Training Pro	Department of Health and Human Services	Department of Health and Human Services	07/01/2012	06/30/2017	Competing Renewal	Awarded
Feinberg School of Medicine	Cardiovascular Epidemiology	SP0021630	SP0021630	60034773	Donald M Lloyd-Jones	Coronary Artery Risk Developme	Department of Health and Human Services	Department of Health and Human Services	07/01/2013	06/30/2016	Competing Renewal	Awarded

Competing Renewal

4

5

Award Type: New

Level 3 Description	Department Description	Level 1 for Institution Number	Institution Number	PeopleSoft Project ID	Full Name	Proposal Short Title	Originating Spon Name Level 1	Sponsor Name Level 1	Project Award Start Date	Project Award End Date	Award Type	Current Proposal Status
Feinberg School of Medicine	Hematology - Oncology	SP0029240	SP0029240		John P Galvin	Exploring the Potential of Dua	Mount Sinai School of Medicine	Mount Sinai School of Medicine	07/01/2014	06/30/2015	New	Awarded
Feinberg School of Medicine	Gen Ob & Gyne Surgery	SP0034607	SP0034607		Melissa A Simon	Contraceptive use, challenges	Society of Family Planning	Society of Family Planning	12/01/2014	06/30/2016	New	Awarded
Feinberg School of Medicine	Pathology	SP0027481	SP0027481		Kathleen Janee Green	Role of desmoglein	Department of Health and Human Services	Department of Health and Human Services	02/03/2015	02/02/2018	New	Awarded
Feinberg School of Medicine	Cardiovascular Epidemiology	SP0034668	SP0034668		Donald M Lloyd-Jones		American Heart Association	University of Alabama System	04/01/2015	03/31/2016	New	Pre-Spending
Feinberg School of Medicine	Physical Therapy	SP0029607	SP0029607		Anamaria Acosta		Department of Health and Human Services	Department of Health and Human Services	04/01/2015	09/30/2015	New	Awarded

InfoEd Workflow: Metrics

- Metrics on award setup time will be deployed to the OSR website Reports and Metrics page
- Still in progress, but an early draft:

Avg Setup Time

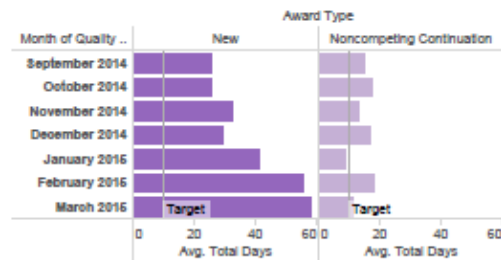

Award Volume

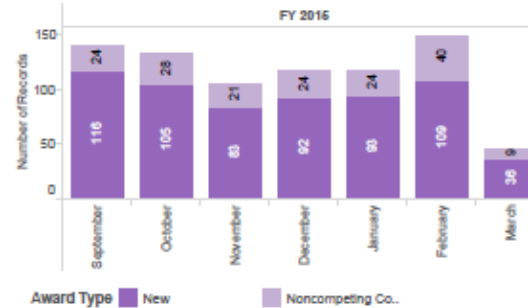

Awards Setup Last Month-Days per Award

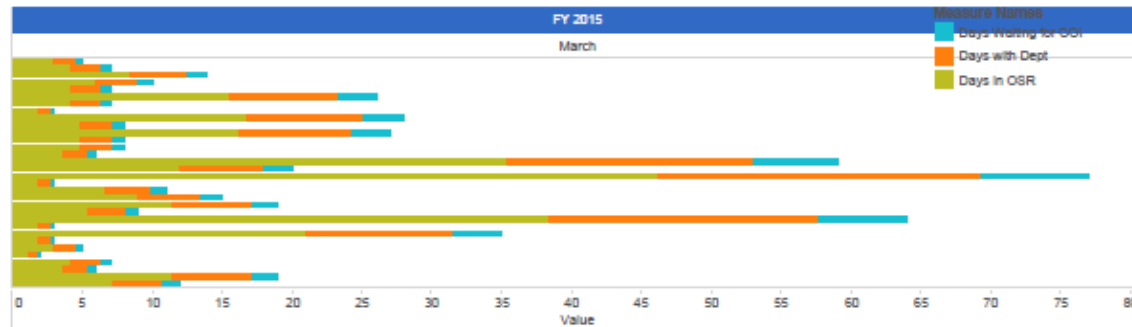

**OTHER UPDATES:
ONBASE, WEBSITE, ESPR**

OnBase InfoEd Integration and Record Retention (R2i2): Project Overview

- Joint project between OSR/ASRSP
- InfoEd Integration:
 - Providing a way for department-based InfoEd users to access proposal/award-specific documents in OnBase
 - Deploying a mechanism to automatically export relevant documents from InfoEd to OnBase
- Record Retention (R2)
 - Developing retention and destruction procedures and policies
 - Configuring OnBase to implement these procedures

OnBase i2: Goals & Requirements

- Standardization
 - Upload and naming conventions to align InfoEd and OnBase and facilitate retrieval
- Compliance
 - E.g. Uniform Guidance reporting requirements
- Access
 - Unified reference point for documents
 - ↑ Access in OnBase = ↓ Storage in InfoEd

OnBase i2: Timeline & Changes

- Fall 2015 Implementation: End of September
- Functional Changes
 - Streamlined InfoEd document type list
 - Link to OnBase on PT Proposal Summary page
- Procedural Changes
 - InfoEd: Document exchange, proposal submissions
 - Proposal Documents (e.g. LOI, Budgets)
 - OnBase: Ultimate system of record
 - Proposal documents from Submitted Proposals in InfoEd transferred automatically to OnBase
 - Proposal, pre-award/JIT, and post-award documents, including final executed agreements (e.g. Final SubK packet)

Website Survey: Results Summary

- Users generally find the site useful, organized, and easy to use.
 - 65% agree or strongly agree with general usefulness, ease of use, and satisfaction questions.
- Most common uses of the website
 - Researching a specific topic
 - Accessing resources and tools
- Areas for improvement
 - Search functionality and organization of information
 - RA-focused tools and resources

Website Survey: Demographics

- Fifty (50) Total Respondents
 - Mostly in RA-related positions (78%)
 - Representative sampling between Evanston (44%) and Chicago (48%) campuses
 - Most respondents have been at NU for > 5 years (64%)

All Respondents: Position

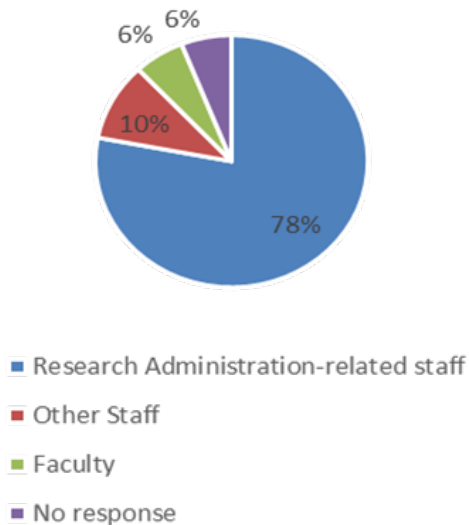

All Respondents: Campus

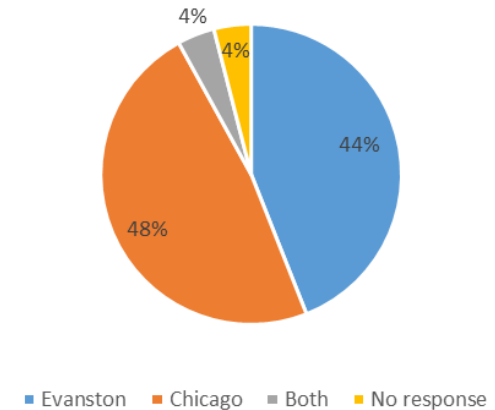

All Respondents: Length of Service

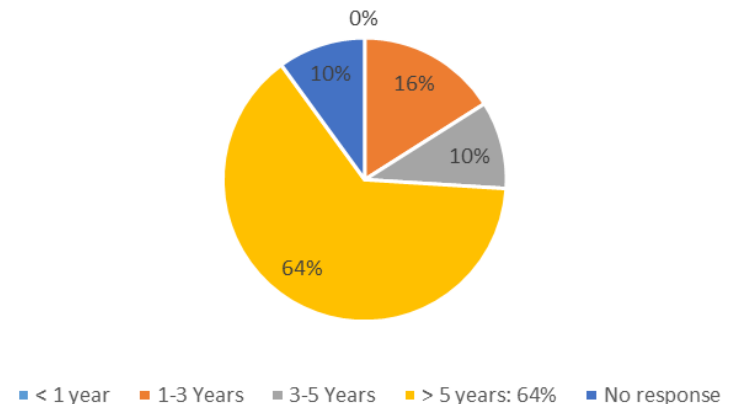

Website survey: Notable findings

- **Campus**
 - No significant differences between campuses.
- **By position**
 - Faculty: Lower ratings for usefulness and grants management information BUT higher ratings for usefulness of quick links and resources / training sections
 - Non-RA staff: Higher ratings across all dimensions and features.
- **Unique features of RA staff of 3-5 years**
 - Rated the website higher on questions of general usefulness, satisfaction, and site features.
 - Reported NO use of website for finding out about news and events or for accessing electronic systems (e.g. InfoEd)

Website Progress & Next Steps

- Project Goals & Strategy
 - **Goal:** Create an Organized, Informative, and Consistent site
 - **Strategy:**
 - Phase 1: Critical sections and tools and as many key sub-pages as possible.
 - Phase 2: Revisions to address primary constituent needs based on feedback.
- Status
 - Completed Phase 1 successfully BUT still have some issues to address, namely content organization and tools
- Next Steps: Coordinated effort with OSR Training Initiative to address identified pain points
 - Update search functionality and tweak pages for improved search results
 - More robust Research Administration tools and resources (e.g. templates, job aides, RA intro training)
 - RA staff-focused organization of information
 - Consistency, consistency, consistency!

ESPR 3.0 Overview

- Focus of this phase of development
 1. Routing issues
 2. Information processing issues
- Specific functional items to be addressed:
 1. Develop administrative module
 2. Edit existing forms (e.g. add/edit/delete questions)
 3. Develop new forms
 4. Tweaking general system functionality
- Timeline: Fall 2015
 - Expected Launch: December 2015

Questions?

- InfoEd – Sara Krentz, s-krentz@northwestern.edu
- OnBase, Website, ESPR – Melissa Mizwa, mmizwa@northwestern.edu